

No. 22-976

---

IN THE  
**Supreme Court of the United States**

MERRICK B. GARLAND, ATTORNEY GENERAL, ET AL.,  
*Petitioners,*

v.

MICHAEL CARGILL,  
*Respondent.*

---

**On Writ of Certiorari  
to the United States Court of Appeals  
for the Fifth Circuit**

---

**BRIEF OF GIFFORDS LAW CENTER TO  
PREVENT GUN VIOLENCE, BRADY CENTER  
TO PREVENT GUN VIOLENCE, EVERYTOWN  
FOR GUN SAFETY, AND MARCH FOR OUR  
LIVES AS *AMICI CURIAE* IN SUPPORT OF  
PETITIONERS**

---

STEPHEN J. MCINTYRE  
O'MELVENY & MYERS LLP  
400 South Hope Street  
Los Angeles, CA 90071

ANNA T. PLETCHER  
O'MELVENY & MYERS LLP  
Two Embarcadero Center  
28th Floor  
San Francisco, CA 94111

VINCENT WEISBAND  
O'MELVENY & MYERS LLP  
7 Times Square  
New York, NY 10036

IAN SIMMONS  
*Counsel of Record*  
SERGEI ZASLAVSKY  
DAVID K. ROBERTS  
EMILY MURPHY  
O'MELVENY & MYERS LLP  
1625 Eye Street, NW  
Washington, DC 20006  
(202) 383-5300  
isimmons@omm.com

*Attorneys for Amici Curiae*

---

**TABLE OF CONTENTS**

	<b>Page</b>
INTEREST OF <i>AMICI CURIAE</i> .....	1
INTRODUCTION AND SUMMARY OF THE ARGUMENT.....	2
ARGUMENT .....	7
I. Bump Stocks Convert Semi-Automatic Rifles Into Machineguns. ....	7
A. Semi-automatic rifles and automatic rifles have few mechanical differences. ....	8
B. Bump stocks convert the semi-automatic firing process into an automatic one.....	11
C. Bump stocks enable fire rates rivaling those of conventional automatic weapons. ....	13
D. Manufacturer advertising confirms that rifles equipped with bump stocks are machineguns. ....	14
II. The ATF Rule Accords With The NFA’s Text, History, And Design To Prevent Circumvention Of The Machinegun Ban.....	15
A. Congress has repeatedly expanded the definition of “machinegun” to counteract efforts to design around the NFA.....	16
B. The ATF rule effectuates congressional effort to prevent workarounds. ....	19

**TABLE OF CONTENTS**  
(continued)

	<b>Page</b>
III. The ATF Rule Recognizes The Uniquely Pernicious Threats That Unregulated Bump Stocks Pose To Society. ....	21
IV. The Rule Of Lenity Has No Role To Play In This Case. ....	24
CONCLUSION.....	27

## TABLE OF AUTHORITIES

	Page(s)
<b>Cases</b>	
<i>Abramski v. United States</i> , 573 U.S. 169 (2014).....	5, 21
<i>Bell v. United States</i> , 349 U.S. 81 (1955).....	26
<i>Callanan v. United States</i> , 364 U.S. 587 (1961).....	26
<i>Guedes v. ATF</i> , 45 F.4th 306 (D.C. Cir. 2022) .....	19, 20
<i>Hardin v. ATF</i> , 65 F.4th 895 (6th Cir. 2023) .....	24
<i>Moskal v. United States</i> , 498 U.S. 103 (1990).....	25
<i>Ocasio v. United States</i> , 578 U.S. 282 (2016).....	25
<i>Pugin v. Garland</i> , 599 U.S. 600 (2023).....	25
<i>Reno v. Koray</i> , 515 U.S. 50 (1995).....	25
<i>Staples v. United States</i> , 511 U.S. 600 (1994).....	3, 15, 20
<i>United States v. Davis</i> , 139 S.Ct. 2319 (2019).....	26
<i>United States v. Kozminski</i> , 487 U.S. 931 (1988).....	25

**TABLE OF AUTHORITIES**  
(continued)

	<b>Page(s)</b>
<i>United States v. Palmer</i> , 16 U.S. (3 Wheat.) 610 (1818) .....	26
<i>United States v. Wiltberger</i> , 18 U.S. (5 Wheat.) 76 (1820) .....	27
<i>Wooden v. United States</i> , 595 U.S. 360 (2022).....	25
<b>Constitutional Provisions</b>	
U.S. Const. amend. I.....	21
<b>Statutes</b>	
26 U.S.C. § 5845(b).....	2, 5, 7, 10-11, 15, 19-20
Pub. L. No. 73-474, 48 Stat. 1236 (1934) .....	2, 17
Pub. L. No. 90-618, 82 Stat. 1213 (Oct. 22, 1968).....	18
Pub. L. No. 99-308, 100 Stat. 449 (1986) .....	2, 18
<b>Regulations</b>	
83 Fed. Reg. 7,949 (Feb. 20, 2018).....	4
83 Fed. Reg. 13,442 (Mar. 29, 2018).....	23
83 Fed. Reg. 66,514 (Dec. 26, 2018).....	4, 19-20, 22-23
<b>Other Authorities</b>	
45Snipers, <i>How An AR-15 Rifle Works: Part 2, Function</i> , YouTube (Jan. 11, 2017) .....	9
Alexis de Tocqueville, <i>Democracy in America</i> 489 (Mansfield & Winthrop eds. 2000) .....	21

**TABLE OF AUTHORITIES**  
(continued)

	<b>Page(s)</b>
Amy Coney Barrett, <i>Substantive Canons and Faithful Agency</i> , 90 B.U. L. Rev. 109 (2010).....	26
ArmaLite, Inc., Technical Note 54: Direct Impingement Versus Piston Drive (July 3, 2010) .....	8
Brian Knight, <i>State Gun Policy and Cross-State Externalities: Evidence from Crime Gun Tracing</i> , 5 Am. Econ. J: Econ. Pol’y 200 (2013).....	23
Daniella Silva et al., <i>Las Vegas Shooting Survivors Grieve One Year Later: ‘You’re Missing Your Soul Mate’</i> , NBCNews.com (Sept. 29, 2018).....	22
David T. Hardy, <i>The Firearms Owners’ Protection Act: A Historical and Legal Perspective</i> , 17 Cumb. L. Rev. 585 (1987) .....	18
Ed Leefeldt, <i>Stephen Paddock Used a “Bump Stock” to Make His Guns Even Deadlier</i> , CBS News (Oct. 4, 2017) .....	23
Erik J. Olson et al., <i>American Firearm Homicides: The Impact of Your Neighbors</i> , 86 J. Trauma & Acute Care Surgery 797 (2019).....	24
Firequest, Slide Fire SSAK-47 Bump Fire Stock – Right Hand Model.....	15

**TABLE OF AUTHORITIES**  
(continued)

	<b>Page(s)</b>
Firequest, Slide Fire SSAR-15 Bump Fire Stock – Right Hand Model.....	15
H.R. Rep. No. 73-1780 (1934) .....	16, 17
Hearings Before a Subcommittee of the Committee on Commerce of the United States Senate on S.885, S.2258 and S. 3680 (1934) .....	16
Hearings Before The Committee on Ways and Means, House of Representatives on H.R. 9066 (1934).....	16, 17, 19
Jonathan Bernstein & Mark Gray, <i>Five Years Since the Route 91 Massacre No One Knows a Damn Thing</i> , Rolling Stone (Sept. 21, 2022) .....	3
Las Vegas Metro. Police Dep’t, LVMPD Criminal Investigative Report of the 1 October Mass Casualty Shooting (Aug. 3, 2018) .....	3, 22, 23
Midsouth Shooters, Bumpfire Systems.....	14
<i>Powerful US Gun Lobby Group Backs New Curbs on Rapid-fire Accessories</i> , Straits Times (Oct. 6, 2017).....	13
S. Rep. No. 73-1444 (1934).....	16
Sen. Comm. on the Judiciary, 97th Cong., Federal Regulation of Firearms (1982).....	17, 18

## TABLE OF AUTHORITIES

(continued)

	<b>Page(s)</b>
Slide Fire, <i>Slide Fire: Bump Fire Stocks</i> (Jan. 8, 2014).....	15
Steven Koff, <i>Assault Weapons, Semi-Automatic Rifles and the AR-15: Defining the Debate</i> , Cleveland.com (Apr. 18, 2018) .....	14
<i>The “Bump Stocks” Used in the Las Vegas Shooting May Soon Be Banned</i> , Economist (Oct. 6, 2017) .....	14
Thomas Schwenke, <i>M16 and AR-15 – How Firearms Work!</i> , YouTube (Feb. 23, 2019).....	10, 11
U.S. Ct. App. 5th Cir., Bump Fire Animation .....	12
U.S. Dep’t Army, Field Manual 23-9, Rifle Marksmanship M16A1, M16A2/3, M16A4, and M4 Carbine (Sept. 13, 2006) .....	8, 9, 10, 14
Webster’s New International Dictionary (2d ed. 1934).....	19, 20



## INTEREST OF *AMICI CURIAE*<sup>1</sup>

*Amici curiae* Giffords Law Center to Prevent Gun Violence, Brady Center to Prevent Gun Violence, Everytown for Gun Safety, and March for Our Lives are nonprofit organizations dedicated to reducing gun violence through education, research, and advocacy. *Amici* represent the interests of gun-violence survivors and others who have experienced firsthand the devastating impact that gun violence has on families and communities. *Amici* seek to improve community safety by supporting common-sense gun laws and policies. In furtherance of that goal, *amici* have filed numerous *amicus* briefs, including in bump-stock cases. *See, e.g.*, Brief for Giffords Law Center to Prevent Gun Violence, Brady, and Everytown for Gun Safety as Amici Curiae Supporting Appellees, *Guedes v. ATF*, No. 21-5045 (D.C. Cir. Nov. 8, 2021); Brief for Giffords Law Center to Prevent Gun Violence as Amicus Curiae Supporting Defendants-Appellees, *Cargill v. Garland*, No. 20-51016 (5th Cir. May 14, 2021). Several of *amici* filed a brief in support of petitioners at the petition stage of this case. *Giffords Law Center et al. Amici Br.*, No. 22-976 (filed May 8, 2023).

---

<sup>1</sup> No counsel for any party authored this brief in whole or in part, and no entity or person other than *amici* and their counsel made any monetary contribution toward the preparation or submission of this brief.

## INTRODUCTION AND SUMMARY OF THE ARGUMENT

Nine decades ago, Congress passed the National Firearms Act (“NFA”) to regulate “certain firearms and machine guns.” Pub. L. No. 73-474, 48 Stat. 1236 (1934). The NFA initially required civilians to register machineguns, Pub. L. No. 73-474, §§ 5, 14, but Congress later replaced that scheme with an all-out ban on civilian ownership of newly manufactured machineguns, Pub. L. No. 99-308, 100 Stat. 449 (1986). The NFA defined “machinegun” by its essential features: if a firearm can shoot “automatically ... more than one shot ... by a single function of the trigger,” it is a machinegun. Pub. L. No. 73-474, § 1(b). Over time, though, manufacturers began to circumvent the statute—for example, by producing components that made semi-automatic weapons function like machineguns. That led Congress to broaden the NFA to prohibit devices that “convert[] a weapon into a machinegun.” See Pub. L. No. 99-308, § 109(a), *codified at* 26 U.S.C. § 5845(b). This approach is logical: if an invention turns an ordinary gun into a machinegun, it is a machinegun.

“Bump stocks” turn semi-automatic rifles into machineguns. That is their sole purpose. When a rifle is outfitted with a bump stock, the shooter need only pull the trigger once, and the gun will fire continuously so long as the shooter keeps his trigger finger stationary and applies forward pressure to the barrel. Put simply, the bump stock makes the rifle “fire[] repeatedly with a single pull of the trigger.” *Staples v.*

*United States*, 511 U.S. 600, 602 n.1 (1994) (construing the NFA’s definition of “machinegun”). That makes it a machinegun.

The horrific mass shooting in Las Vegas on October 1, 2017, showed what can happen when a bump stock turns a rifle into a machinegun. A gunman, perched in a hotel window on the Las Vegas strip, opened fire on thousands of concertgoers below using several legally purchased AR-15-style rifles equipped with bump stocks. In 11 minutes, he wounded nearly 500 people, killing 60.<sup>2</sup> It remains the deadliest mass shooting in American history.

Only automatic weapons can inflict so many casualties so quickly. Numerous witnesses, including police officers, described hearing “automatic gunfire.”<sup>3</sup> That is exactly what it was: bump stocks allowed the gunman to fire more than 1,000 rounds in 11 minutes.<sup>4</sup>

In the wake of the 1 October shooting, the Justice Department’s Bureau of Alcohol, Tobacco, Firearms and Explosives (“ATF”) issued an advance notice of proposed rulemaking as a first step in examining whether bump stocks fall within the statutory defini-

---

<sup>2</sup> This figure includes two victims who later died from their injuries. See Jonathan Bernstein & Mark Gray, *Five Years Since the Route 91 Massacre No One Knows a Damn Thing*, Rolling Stone (Sept. 21, 2022), <https://tinyurl.com/bdjvkvk2>.

<sup>3</sup> See Las Vegas Metro. Police Dep’t, LVMPD Criminal Investigative Report of the 1 October Mass Casualty Shooting 7, 34-36, 40-41, 56-57, 58, 73 (Aug. 3, 2018).

<sup>4</sup> *Id.* at 125.

tion of machineguns. In February 2018, then-President Trump directed the Attorney General “to dedicate all available resources to complete the review of the comments received [from the advance notice of proposed rulemaking], and, as expeditiously as possible, to propose for notice and comment a rule banning all devices that turn legal weapons into machineguns.”<sup>5</sup> The ATF then published a proposed rule and, in December 2018, issued a final rule that defines all bump stocks as machineguns.<sup>6</sup> Certain individuals and organizations, including Respondent, challenged the ATF rule in court, and the Fifth Circuit sustained their position, ruling that bump stocks are not machineguns. Pet. App. 3a.

The Fifth Circuit’s decision is wrong and dangerous. If this Court does not correct the ruling, it will make every American less safe. *Amici* urge the Court to uphold the ATF rule for the following reasons:

First, the ATF correctly determined that bump stocks mechanically convert semi-automatic rifles into fully automatic weapons. In semi-automatic rifles, a “disconnecter” ensures that each pull of the trigger fires just one round. With automatic rifles, once the shooter pulls the trigger and fires a round, the disconnecter is disabled and an “auto sear” harnesses that combustion reaction’s kinetic force to load and fire another round—without requiring a new trigger pull. Bump stocks retool a rifle’s disconnecter to

---

<sup>5</sup> Application of the Definition of Machinegun to “Bump Fire” Stocks and Other Similar Devices, 83 Fed. Reg. 7,949 (Feb. 20, 2018).

<sup>6</sup> Bump-Stock-Type Devices, 83 Fed. Reg. 66,514 (Dec. 26, 2018).

function like an auto sear, leveraging the back-and-forth movement from the same combustion reaction to enable continuous firing. This action increases the rifle's rate of fire dramatically, rivaling that of a weapon equipped with an auto sear—a fact gun manufacturers highlight. We provide below a straightforward technical description, with diagrams, of how bump stocks work, and we show how they transform a semi-automatic weapon into a fully automatic one.

Second, the ATF rule reflects the best interpretation of the statute's text, history, and design. Given their mechanics, bump stocks readily satisfy the NFA's definition of "machinegun": a bump stock "convert[s] a weapon" into a firearm that shoots "automatically more than one shot ... by a single function of the trigger." 26 U.S.C. § 5845(b). Over the past century, Congress has repeatedly expanded the definition of "machinegun" to counteract manufacturers' efforts to design around the NFA's prohibition. The ATF rule is consistent with a plain-text (and common-sense) reading of the statute, and it furthers Congress's decision to ban devices that turn semi-automatic weapons into machineguns. The Fifth Circuit's decision disregards the statute's text and frustrates Congress's objective.

Third, the ATF's interpretation furthers the purpose of the machinegun ban to remove these extraordinarily dangerous weapons from the public sphere. *See Abramski v. United States*, 573 U.S. 169, 179 (2014) (court must interpret firearms provision, like all statutory provisions, in light of "statutory context, structure, history, and purpose") (internal quotation marks omitted). Unregulated bump stocks pose a

unique danger to society. Public gatherings—to worship, to protest, to celebrate, to play—are essential to Americans’ way of life and to the health of our religious, political, and social institutions. Because bump stocks dramatically increase a weapon’s fire rate but compromise its accuracy, they are ill-suited for sport shooting or lawful self-defense—they are only suited for spraying many bullets in a short time. In the hands of a gunman bent on killing as many people as possible, they are a tool for indiscriminate murder: one need only aim a bump-stock-equipped rifle at a crowd and pull the trigger once. The ATF rule addresses this singularly pernicious threat to public life.

Fourth, the Fifth Circuit’s decision striking down the ATF rule rests on a novel holding that would require judgment in favor of criminal defendants whenever a court perceives any ambiguity in a criminal statute. The ATF’s rule is consistent with the clear meaning of the statute, foreclosing any need to turn to the rule of lenity. But in any event, this Court’s cases have articulated a far more stringent test, requiring exhaustion of all tools of statutory construction before invoking this rule. Because nothing approaching that high level of ambiguity exists here, the Court should hold that the rule of lenity does not foreclose the ATF rule.

For these reasons, the Court should reverse the Fifth Circuit’s decision.

## ARGUMENT

### I. **Bump Stocks Convert Semi-Automatic Rifles Into Machineguns.**

Bump stocks exist for one reason: to convert semi-automatic rifles into machineguns. A machinegun's internal parts harness the recoil motion of the gun to maintain automatic fire after a trigger pull. Bump stocks are external attachments that do the same thing. A bump stock therefore satisfies the statutory test: it is "designed and intended solely and exclusively" to "convert[] a weapon into a machinegun." 26 U.S.C. § 5845(b).

The technical operation of bump stocks confirms this conclusion. Automatic and semi-automatic rifles have very similar firing mechanisms. In semi-automatic rifles, the firing process is controlled by a "disconnecter," which requires each shot to be fired manually (*i.e.*, with a trigger pull). In rifles designed to fire automatically, a trigger pull disengages the disconnecter, and the auto sear then controls the firing process. The auto sear harnesses the kinetic force created by the combustion reaction that fires each round to load and fire a new round without additional operator action. Bump stocks harness the back-and-forth movement from the same combustion reaction, allowing the disconnecter cycle to loop and the gun to continuously fire, without the need for the shooter to make repeated trigger pulls. This turns a semi-automatic weapon into an automatic weapon.

### A. Semi-automatic rifles and automatic rifles have few mechanical differences.

Most automatic and semi-automatic rifles use a “gas operating” system to eject and reload new rounds after firing.<sup>7</sup> Consider the military’s standard-issue M16 automatic rifle and its semi-automatic civilian counterpart, the AR-15-style rifle:

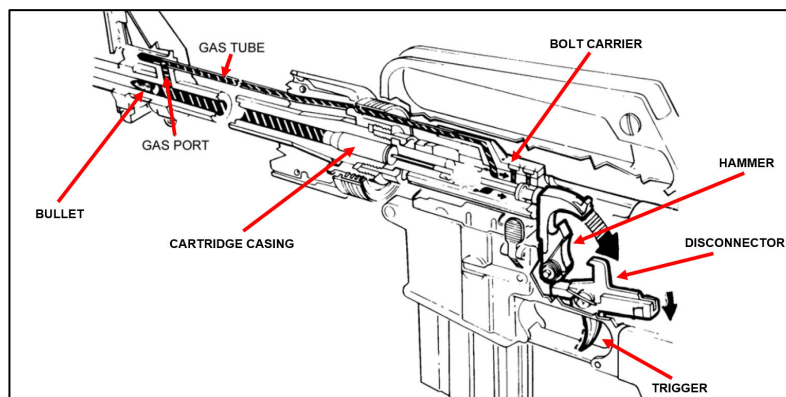

**Figure 1: Diagram of Gas Operating System of M16- and AR-15-Style Rifles<sup>8</sup>**

To prepare either gun to fire, the bolt locks a round of ammunition into firing position. FM23-9 ¶ 4-2. When the shooter pulls the trigger, the hammer strikes the firing pin, igniting the gunpowder housed in the round. *Id.* The resulting explosion causes rapidly expanding gas to propel the bullet forward. *Id.* As the bullet exits the barrel, the rifle diverts some of the

<sup>7</sup> ArmaLite, Inc., Technical Note 54: Direct Impingement Versus Piston Drive (July 3, 2010), <https://tinyurl.com/mr242pue>.

<sup>8</sup> U.S. Dep’t Army, Field Manual 23-9, Rifle Marksmanship M16A1, M16A2/3, M16A4, and M4 Carbine (“FM23-9”) ¶ 4-2 (Sept. 13, 2006).



expanding gas back toward the rear of the rifle to push the bolt carrier—which houses the bolt—backward, ejecting the spent cartridge casing and resetting the hammer. *Id.* A buffer spring at the back of the rifle then propels the bolt carrier forward to collect a new cartridge from the magazine and lock it into firing position. *Id.*

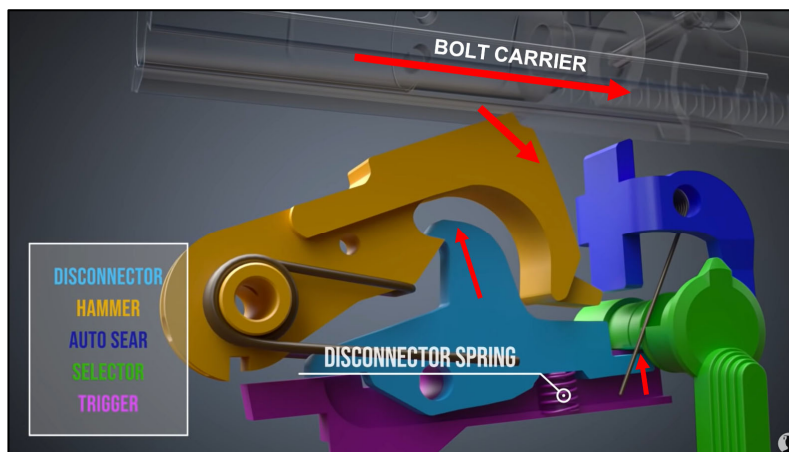

**Figure 2: Post-Fire Forward Motion of Bolt Carrier<sup>9</sup>**

The primary difference between automatic and semi-automatic rifles lies in the firing mechanism. For both types of rifles, the initial trigger pull releases the hammer to fire a round. FM23-9 ¶¶ 4-2, 4-3. The bolt carrier then cocks the hammer back, readying it to release again to fire the next shot. *Id.* ¶ 4-2. In a semi-automatic rifle, a spring pushes the disconnecter up to catch the hammer as the bolt carrier cocks it back, preventing the hammer from releasing until the shooter pulls the trigger again. *Id.* The dis-

<sup>9</sup> 45Snipers, *How An AR-15 Rifle Works: Part 2, Function*, YouTube (Jan. 11, 2017), <https://youtu.be/wAqE-KLbiYc>.

connector thereby disrupts the otherwise “auto-  
matic[]” cycle of firing, requiring another “function of  
the trigger” to fire again. *Cf.* 26 U.S.C. § 5845(b).

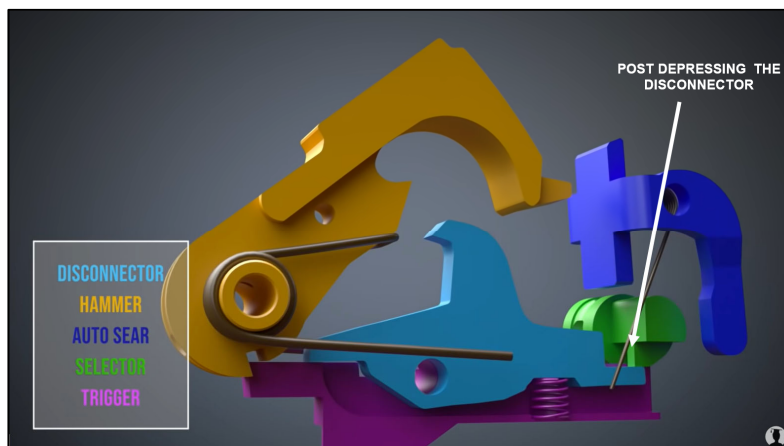

**Figure 3: Post-Fire Mechanism—M16 in Semi-Automatic Mode<sup>10</sup>**

In the automatic M16 rifle, by contrast, a post on the selector switch—the part used to toggle between different fire modes—prevents the disconnecter from rising to catch the hammer after each shot. FM23-9 ¶ 4-3. Instead, the firing mechanism is governed by the auto sear, which catches the hammer as the bolt carrier cocks it back after firing a round. *Id.* When the bolt carrier rebounds forward, it pushes the auto sear down, releasing the hammer and firing another round. *Id.*

---

<sup>10</sup> Thomas Schwenke, *M16 and AR-15 – How Firearms Work!*, YouTube (Feb. 23, 2019), <https://youtu.be/wMIBUIN30yU>.



**Figure 4: Firing Mechanism—M16 in Fully Automatic Mode<sup>11</sup>**

The auto sear allows the gun to harness the bolt carrier’s back-and-forth motion caused by the combustion reaction to continuously fire until the trigger is released. The first pull or “function” of the trigger initiates “automatic[]” firing of “more than one shot”—each subsequent round is fired not by new operator action, but by the reaction caused by the firing of the previous round. *See* 26 U.S.C. § 5845(b). That is what makes the weapon automatic, and thus a machinegun.

**B. Bump stocks convert the semi-automatic firing process into an automatic one.**

A bump stock attached to a semi-automatic rifle employs the recoil from the combustion reaction—like any other automatic gun—to reengage the hammer after each round is fired. The disconnecter-to-hammer

---

<sup>11</sup> Schwenke, *supra* note 10.

cycle repeats continuously until the shooter acts to stop the cycle.

A bump stock allows the rifle to slide within the stock. The recoil from each shot, combined with forward pressure from the operator's non-shooting hand (or a spring in some bump stocks), causes the rifle to slide back and forth, "bumping" the operator's stationary trigger finger, which rests on the bump stock's "trigger ledge." Each bump initiates a new firing sequence, allowing the hammer to fire another round without the shooter acting to pull the trigger.



**Figure 5: Pre-Firing Position of Bump Stock with Trigger Finger on Trigger Ledge<sup>12</sup>**

---

<sup>12</sup> U.S. Ct. App. 5th Cir., Bump Fire Animation, [https://www.ca5.uscourts.gov/opinions/pub/20/20-51016\\_bump\\_fire\\_animation.gif](https://www.ca5.uscourts.gov/opinions/pub/20/20-51016_bump_fire_animation.gif) (visited Dec. 17, 2023) (cited in Pet. App. 9a).

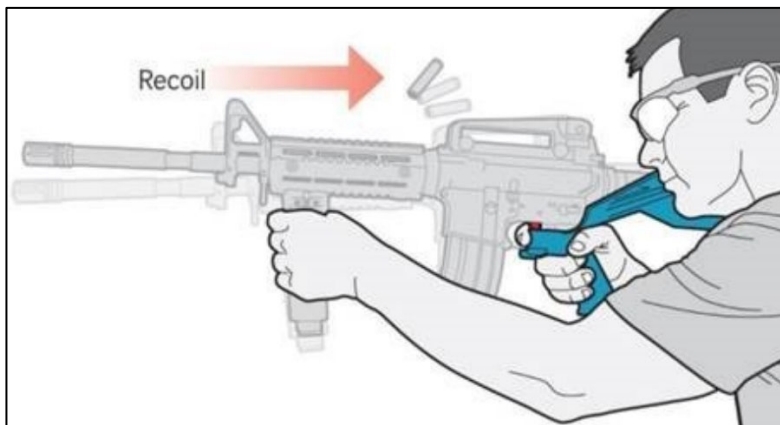

**Figure 6: Bump Stock Firing**<sup>13</sup>

Like a traditional automatic rifle, a bump stock links the firing of each round to the back-and-forth motion caused by the prior round's combustion, allowing continuous fire without the shooter repeatedly pulling the trigger. The only difference is how that kinetic energy is harnessed: by the bolt carrier (traditional automatic rifle) or the entire rifle (bump-stock-equipped rifle). So long as the shooter keeps a finger on the trigger ledge and holds the gun in place by applying forward pressure to the barrel, a bump-stock-equipped rifle will fire continuously.

### **C. Bump stocks enable fire rates rivaling those of conventional automatic weapons.**

Bump stocks dramatically increase weapons' fire rate. A firearm's cyclic fire rate is measured by the time between firing a loaded round and locking a new

<sup>13</sup> *Powerful US Gun Lobby Group Backs New Curbs on Rapid-fire Accessories*, Straits Times (Oct. 6, 2017), <https://www.straitstimes.com/world/united-states/after-las-vegas-shooting-momentum-builds-for-ban-of-rapid-fire-devices>.

round into firing position. FM23-9 at Glossary 7. The military-issue M16 has a cyclic fire rate of 800 rounds per minute (“RPM”). *Id.* ¶ 2-1. Semi-automatic rifles cannot achieve this rate because they are limited by the shooter’s trigger finger—professional sport-shooting competitors have a maximum theoretical firing rate of about 180 RPM.<sup>14</sup> But when outfitted with a bump stock, semi-automatic rifles can fire between 400 and 800 RPM.<sup>15</sup> Bump stocks enable even minimally skilled shooters to match military weapons’ firing rates—underscoring that bump-stock-equipped rifles are machineguns.

**D. Manufacturer advertising confirms that rifles equipped with bump stocks are machineguns.**

Gun manufacturers do not shy away from the fact that bump stocks turn semi-automatic weapons into machineguns. Indeed, that is the device’s selling point. As one manufacturer proudly states, “Bumpfire Stocks are the closest you can get to full auto and still be legal.”<sup>16</sup> Another manufacturer abandons any pre-

---

<sup>14</sup> Steven Koff, *Assault Weapons, Semi-Automatic Rifles and the AR-15: Defining the Debate*, Cleveland.com (Apr. 18, 2018), [https://www.cleveland.com/nation/2018/04/assault\\_weapons\\_semi-automatic\\_1.html](https://www.cleveland.com/nation/2018/04/assault_weapons_semi-automatic_1.html).

<sup>15</sup> See *The “Bump Stocks” Used in the Las Vegas Shooting May Soon Be Banned*, Economist (Oct. 6, 2017), <https://www.economist.com/graphic-detail/2017/10/06/the-bump-stocks-used-in-the-las-vegas-shooting-may-soon-be-banned>.

<sup>16</sup> Midsouth Shooters, Bumpfire Systems, <https://www.midsouthshooterssupply.com/b/bumpfire-systems> (visited Dec. 17, 2023).

tense of civilian use, marketing its product as “Standard Battle Style.”<sup>17</sup> Others specifically advertise bump stocks’ ability to bypass fire-rate limitations inherent to semi-automatic rifles.<sup>18</sup>

These slogans confirm the obvious: a bump stock modifies a semi-automatic rifle so that it “fires repeatedly with a single pull of the trigger.” *Staples*, 511 U.S. at 602 n.1. That is a machinegun.

## **II. The ATF Rule Accords With The NFA’s Text, History, And Design To Prevent Circumvention Of The Machinegun Ban.**

Congress explicitly designed the NFA’s machinegun ban to prevent circumvention: it reaches devices that turn ordinary guns into machineguns. See 26 U.S.C. § 5845(b). The ATF’s bump-stock rule is consistent with the statute’s clear language, history, and purpose. And it furthers an objective that Congress has twice reiterated: gunmakers may not invent around the NFA’s prohibitions with technical contrivances.

---

<sup>17</sup> Firequest, Slide Fire SSAR-15 Bump Fire Stock – Right Hand Model, <https://www.firequest.com/AB227.html> (visited Dec. 17, 2023).

<sup>18</sup> *E.g.*, Slide Fire, *Slide Fire: Bump Fire Stocks* (Jan. 8, 2014), <https://youtu.be/hCCT8JtwQeI> (hailing Bump Fire Stock’s ability to allow gun owners to fire rifles as “quickly as desired”); Firequest, Slide Fire SSAK-47 Bump Fire Stock – Right Hand Model, <https://www.firequest.com/product654.html> (visited Dec. 17, 2023) (“Simple modification for an AK-47 rifle that allows operator to shoot *as quickly as desired.*”) (emphasis added).

**A. Congress has repeatedly expanded the definition of “machinegun” to counteract efforts to design around the NFA.**

The menace from machineguns is not new. Recognizing that machineguns were a “weapon of choice” among armed gangsters of the 1920s and ’30s, Congress imposed a registration requirement and hefty taxes on machineguns by way of the NFA. *See, e.g.*, S. Rep. No. 73-1444, at 1-2 (1934) (“[The] law violator must be deprived of his most dangerous weapon, the machine gun.”); H.R. Rep. No. 73-1780, at 1 (1934) (same). The NFA reflected Congress’s judgment that machineguns have no legitimate civilian purpose, because they were neither necessary nor even useful for sport or self-defense. *See* S. Rep. No. 73-1444, at 2 (1934) (“[T]here is no reason why anyone except a law officer should have a machine gun or sawed-off shotgun.”); H.R. Rep. No. 73-1780, at 1 (1934) (same).

Congress was wary of efforts to circumvent the regulation. As originally proposed, the NFA defined “machinegun” as “any weapon designed to shoot automatically or semiautomatically twelve or more shots without reloading.” Hearings Before a Subcommittee of the Committee on Commerce of the United States Senate on S.885, S.2258 and S. 3680, at 75 (1934). But the National Rifle Association’s then-President, Karl T. Frederick, expressed concern that the definition was too narrow. He noted that firearm manufacturers could bypass the new restrictions simply by limiting a gun’s ammunition-feeding device to hold 11 rounds or fewer. *See* Hearings Before The Committee on Ways and Means, House of Representatives on H.R. 9066, at 39-40 (1934) (“House NFA Hearing”) (“A gun



which fires automatically or semiautomatically less than 12 shots is not under this definition a machine gun. And yet, in my opinion, it is in fact a machine gun and should be so classified.”).

Frederick proposed a broad definition to thwart workarounds: a weapon that “shoots automatically more than one shot without manual reloading, by a single function of the trigger” is a machinegun. *Id.* at 40. Frederick explained that “[t]he distinguishing feature of a machine gun is that by a single pull of the trigger the gun continues to fire as long as there is any ammunition in the belt or in the magazine.” *Id.* By contrast, non-machineguns are limited by how “fast ... you can pull your trigger.” *Id.* at 41. This focus on the human factor—the need to pull a trigger—tracked Congress’s intent to distinguish guns used for sport and self-defense from those useful only for crime. *See* Pub. L. No. 73-474, § 1(b). Congress eventually adopted Frederick’s definition in full. House NFA Hearing at 83; *see* H.R. Rep. No. 73-1780, at 2 (noting the bill’s “usual definition of machine gun as a weapon designed to shoot more than one shot without reloading and by a single pull of the trigger”).

Three decades later, gun violence continued to plague the nation. Despite the NFA’s expansive definition of machinegun, manufacturers managed to circumvent the statute by producing components that converted semi-automatic weapons to fully automatic machineguns. At the time, these converted machineguns accounted for 20 percent of machineguns seized or purchased by the ATF. *See* Sen. Comm. on the Judiciary, 97th Cong., Federal Regulation of Fire-

arms 26 (1982). A government task force recommended that Congress authorize the ATF to expand its machinegun definition to include these conversion kits. *Id.*

Congress again acted to root out workarounds, first by enacting the Gun Control Act of 1968 (“GCA”). Pub. L. No. 90-618, 82 Stat. 1213 (Oct. 22, 1968). In relevant part, the GCA expanded the NFA’s machinegun definition to include “any combination of parts designed and intended for use in converting a weapon into a machinegun.” *Id.* at 1231.

In 1986, Congress went still further. The Firearms Owners’ Protection Act replaced the prior registration scheme with a complete ban on civilian ownership of newly manufactured machineguns. Pub. L. No. 99-308, § 102(9). Faced with a new generation of manufacturer workarounds, Congress broadened the definition of machinegun to capture not only “combination[s] of parts” that could convert a weapon into a machinegun, but *any part* used to convert a weapon into a machinegun. *Id.* § 109(a). This expanded definition targeted manufacturers that had skirted the “combination of parts” provision by designing individual parts capable of converting semi-automatic weapons into automatic weapons.<sup>19</sup>

Time and again, Congress has made clear that the NFA’s machinegun prohibition applies to workarounds that turn ordinary guns into machineguns.

---

<sup>19</sup> David T. Hardy, *The Firearms Owners’ Protection Act: A Historical and Legal Perspective*, 17 *Cumb. L. Rev.* 585, 668 (1987).

**B. The ATF rule effectuates congressional effort to prevent workarounds.**

As amended, the NFA’s machinegun ban unambiguously prohibits devices that cause semi-automatic weapons to function as machineguns. *See* 26 U.S.C. § 5845(b). The ATF’s bump-stock rule both furthers that policy and comports with the best interpretation of the statute. A “machinegun” is “any weapon which shoots, is designed to shoot, or can be readily restored to shoot, automatically more than one shot, without manual reloading, by a single function of the trigger.” 26 U.S.C. § 5845(b). As the D.C. Circuit correctly noted in *Guedes v. ATF* (“*Guedes II*”), 45 F.4th 306 (D.C. Cir. 2022), *reh’g en banc denied*, 66 F.4th 1018 (D.C. Cir. 2023), *petition for cert. pending*, No. 22-1222, the ATF rule’s validity turns on the interpretation of two phrases: “single function of the trigger” and “automatically.” *Id.* at 314. For both phrases, the ATF’s interpretation tracks their ordinary meaning at the time Congress enacted the NFA.

The ATF interprets “single function of the trigger” as “‘single pull of the trigger’ and analogous motions.” 83 Fed. Reg. at 66,515. At the time of the NFA’s enactment, the term “function” was defined as “to perform, execute” or as “activity; doing; performance.” *Function*, Webster’s New International Dictionary (2d ed. 1934). In the context of the NFA, “the shooter’s pull is the single ‘activity’ or ‘performance’ of the trigger that causes the gun to shoot automatically more than one shot.” *Guedes II*, 45 F.4th at 315; *see also* House NFA Hearing at 41 (emphasizing “a single pull” as the “distinguishing feature of a machine

gun”). This Court has recognized as much. *See Staples*, 511 U.S. at 602 n.1 (weapons that “fire[] repeatedly with a single pull of the trigger ... are ‘machineguns’ within the meaning of the Act”).

The ATF defines “automatically” as “the result of a self-acting or self-regulating mechanism that allows the firings of multiple rounds.” 83 Fed. Reg. at 66,554. This definition intentionally draws on the 1934 definition of “automatic.” *Automatic*, Webster’s International Dictionary (2d ed. 1934) (“having a self-acting or self-regulating mechanism that performs a required act at a predetermined point in an operation”); *see* 83 Fed. Reg. at 66,519. The plain meaning of “self-acting or self-regulating mechanism” does not preclude human input; to initiate and maintain fire with an automatic weapon, for example, the shooter must compress and apply continued pressure to the trigger. *See Guedes II*, 45 F.4th at 316-17.

The ATF’s interpretations of these terms provide the “best definition” of machinegun, *id.* at 317, and one that respects the breadth of Congress’s intent. As the ATF found, bump stocks are “designed and intended” for one purpose: to “convert[] a weapon into a machinegun.” 26 U.S.C. § 5845(b); *see* 83 Fed. Reg. at 66,515. By affixing a bump stock to a semi-automatic rifle, a person can “shoot, automatically more than one shot, without manual reloading, by a single function of the trigger.” 26 U.S.C. § 5845(b); *see* 83 Fed. Reg. at 66,518. That is why the ATF rule properly classifies bump stocks as machineguns—and it is why the Fifth Circuit’s decision below was erroneous.

### **III. The ATF Rule Recognizes The Uniquely Pernicious Threats That Unregulated Bump Stocks Pose To Society.**

The ATF's rule also serves Congress's purpose in comprehensively banning machineguns as highly dangerous weapons that have no place in public life. *See Abramski*, 573 U.S. at 179.

Large and open gatherings undergird American civil society and public life. The First Amendment enshrines “the right of the people peaceably to assemble, and to petition the Government” and safeguards the free exercise of religion. U.S. Const. amend. I. Americans exercise these rights by attending political rallies, marching for social causes, and congregating in worship. They also attend music concerts, sports games, marathons, holiday markets and festivals, car races, parades, county and state fairs, and fireworks displays, among myriad other outdoor gatherings. The breadth of causes, hobbies, and interests of an earlier generation of Americans prompted de Tocqueville to observe that “Americans of all ages, all conditions, all minds constantly unite. Not only do they have commercial and industrial associations in which all take part, but they also have a thousand other kinds: religious, moral, grave, futile, very general and very particular, immense and very small.” Alexis de Tocqueville, *Democracy in America* 489 (Mansfield & Winthrop eds. 2000).

These gatherings often draw hundreds if not thousands of people to crowded (and sometimes confined) spaces. Those characteristics render these gatherings uniquely vulnerable to shooters with bump stocks. Bump-stock-equipped rifles spray hundreds of bullets

per minute, albeit at the expense of accuracy—making them impractical for sport or self-defense, but well-suited for devastation and “a particular risk to large-scale public events.” 83 Fed. Reg. at 66,520. As one National Rifle Association member told the ATF, the “only thing bump stocks are good for is creating a kill zone.” *Id.* Merely by pointing the weapon at a crowd from beyond an event’s security perimeter and opening fire, even an inexperienced assailant can murder dozens in little more than the blink of an eye.

The 1 October tragedy in Las Vegas is an all-too-real reminder of the senseless slaughter that bump stocks enable. In just over 10 minutes, the assailant carried out the deadliest shooting in modern U.S. history, shooting more than 600 people and killing 60. One of the scores of deceased, Sonny Melton, was a beloved registered nurse from Big Sandy, Tennessee, who died protecting his wife “from the barrage of bullets raining down on concertgoers as they tried to escape the venue.”<sup>20</sup> Sonny’s wife explained that, beyond impacting herself and her family, “it really devastated an entire community.” This is exactly what the assailant wanted. According to his own brother, the assailant wanted to be known for “having the largest casualty count.”<sup>21</sup> He “planned every part of the attack methodically,” carefully selecting “the hotel, the room, the floor, and the concert venue below.”<sup>22</sup>

---

<sup>20</sup> Daniella Silva et al., *Las Vegas Shooting Survivors Grieve One Year Later: ‘You’re Missing Your Soul Mate’*, NBCNews.com (Sept. 29, 2018), <https://www.nbcnews.com/news/us-news/las-vegas-shooting-survivors-grieve-one-year-later-you-re-n913021>.

<sup>21</sup> LVMPD Criminal Investigative Report, *supra* note 3, at 116.

<sup>22</sup> *Id.* at 116, 118.

His choice of weapon was equally calculated: he had 14 guns equipped with bump stocks and fired 1,049 rounds from those rifles.<sup>23</sup> For security guards and police officers responding to the scene, the gunfire was indistinguishable from that of military-style automatic weapons.<sup>24</sup>

The use of bump stocks to inflict mass carnage in Las Vegas increased the risk that, absent the ATF's rule, these devices would be used in future mass shootings and terror attacks. As the ATF recognized in promulgating its rule, "the Las Vegas tragedy made 'individuals aware that these devices exist—potentially including persons with criminal or terrorist intentions—and made their potential to threaten public safety obvious.'" 83 Fed. Reg. at 66,520 (quoting 83 Fed. Reg. 13,442, 13,447 (Mar. 29, 2018)). Moreover, before the rule, bump stocks were "easily attainable and inexpensive items." *Id.*<sup>25</sup> And though some states have banned bump stocks, these laws are no substitute for the ATF rule, as significant evidence indicates that guns and gun parts originating in states with looser gun laws are often used in crimes in states with stricter laws.<sup>26</sup> Thus, for aspiring killers seeking "the

---

<sup>23</sup> *Id.* at 96-107.

<sup>24</sup> *See id.* at 7, 56, 73.

<sup>25</sup> A search shortly after the 1 October shooting found bump stocks widely available for \$90 to \$200, a far cry from the price tag of a pre-1986 fully automatic rifle, which can reach \$50,000. Ed Leefeldt, *Stephen Paddock Used a "Bump Stock" to Make His Guns Even Deadlier*, CBS News (Oct. 4, 2017), <https://tinyurl.com/5y5r7eht>.

<sup>26</sup> *See* Brian Knight, *State Gun Policy and Cross-State Externalities: Evidence from Crime Gun Tracing*, 5 Am. Econ. J: Econ.

largest casualty count,” the 1 October bump-stock massacre provides a terrifying blueprint.

#### **IV. The Rule Of Lenity Has No Role To Play In This Case.**

Before the Fifth Circuit’s *en banc* decision, the U.S. Courts of Appeals had uniformly upheld the ATF rule. For its part, the Fifth Circuit recognized that a machinegun is characterized by the power to “shoot continuously” with “one pull of the trigger”—and that bump stocks likewise allow a shooter to fire continuously without having to “pull and release his trigger finger.” Pet. App. 8a, 10a. Yet it erroneously held that bump stocks are not machineguns. *Id.* at 3a. The court was deeply fractured; the sole rationale on which a majority could agree was that, under the rule of lenity, any ambiguity in the term “machinegun” should be construed against the Government. *Id.* at 2a n.\*.<sup>27</sup>

Invoking the rule of lenity in this setting was unsound. Even if the definition of “machinegun” were susceptible to multiple meanings, lenity does not permit courts to rewrite statutes whenever they perceive any ambiguity. This Court should curb the Fifth Circuit’s abridgement of congressional authority.

---

Pol’y 200 (2013); Erik J. Olson et al., *American Firearm Homicides: The Impact of Your Neighbors*, 86 J. Trauma & Acute Care Surgery 797 (2019).

<sup>27</sup> Since the Fifth Circuit’s decision, a panel of the Sixth Circuit invoked the rule of lenity to invalidate ATF’s rule (despite a prior decision by an equally divided *en banc* court rejecting a challenge to the rule). See *Hardin v. ATF*, 65 F.4th 895 (6th Cir. 2023), *petition for cert. pending*, No. 23-62. The panel declined to engage the merits at length given the other opinions assessing the validity of the rule. *Id.* at 898.



The problem with the Fifth Circuit’s decision is not just that it is wrong as a matter of statutory construction—though that is ample reason to reverse its judgment. The decision also endorsed a rule that would undo Congress’s intent whenever a court finds any ambiguity in a criminal statute. This Court’s articulation of the rule of lenity requires a far higher degree of ambiguity before courts resort to lenity. Accordingly, while no ambiguity exists after all of the tools of statutory construction are brought to bear, the Fifth Circuit’s approach would be wrong even if this Court found some ambiguity.

The rule of lenity comes into play “only when a criminal statute contains a grievous ambiguity or uncertainty, and only if, after seizing everything from which aid can be derived, the Court can make no more than a guess as to what Congress intended.” *Ocasio v. United States*, 578 U.S. 282, 295 n.8 (2016) (quotations omitted); see *Pugin v. Garland*, 599 U.S. 600, 610 (2023) (same); *Wooden v. United States*, 595 U.S. 360, 376-77 (2022) (Kavanaugh, J., concurring) (“explain[ing] why the rule of lenity has appropriately played only a very limited role in this Court’s criminal case law”). For lenity to apply, it is not enough that there is a “division of judicial authority” or that it is “possible to articulate a construction more narrow than that urged by the Government.” *Moskal v. United States*, 498 U.S. 103, 108 (1990) (emphasis omitted); see also *Reno v. Koray*, 515 U.S. 50, 64-65 (1995).

Lenity helps “maintain the proper balance between Congress, prosecutors, and courts.” *United States v. Kozminski*, 487 U.S. 931, 952 (1988).

Properly applied, it ensures the Judiciary does not overstep constitutional limits by criminalizing conduct where Congress has not. *See United States v. Davis*, 139 S. Ct. 2319, 2333 (2019). But resorting to lenity where principles of statutory construction would suffice frustrates rather than furthers congressional intent: “The rule comes into operation at the end of the process of construing what Congress has expressed, not at the beginning as an overriding consideration of being lenient to wrongdoers. That is not the function of the judiciary.” *Callanan v. United States*, 364 U.S. 587, 596 (1961).

Where the Judiciary can ascertain Congress’s intent, lenity has no role. *See Bell v. United States*, 349 U.S. 81, 83 (1955). Otherwise, the best interpretation of a statute would invariably give way to the narrowest. This Court has long rejected that view. *E.g.*, *United States v. Palmer*, 16 U.S. (3 Wheat.) 610, 629 (1818); *cf.* Amy Coney Barrett, *Substantive Canons and Faithful Agency*, 90 B.U. L. Rev. 109, 131 (2010) (“This insistence upon legislative supremacy is a constant refrain in the case law regarding the canon [of lenity].... Over and over again, courts stressed that they were obliged to choose the best, not the narrowest interpretation of a statute.”).

The Fifth Circuit’s invocation of lenity to strike down the ATF rule disregarded these bedrock principles. The majority began by asking whether any assumed ambiguity in the NFA “should be resolved in favor of lenity.” Pet. App. 41a (internal quotation marks omitted). It answered simply: “the rule of lenity applies if the statute is ambiguous.” *Id.* That was no slip; the majority repeatedly emphasized that *any*

ambiguity warrants lenity. *E.g., id.* at 44a (“[A]ssuming the definition of machinegun is ambiguous, we are bound to apply the rule of lenity.”). And because the “definition of ‘machinegun’ ... is ambiguous, at the very least,” the court said, lenity “compel[led]” it “to construe the statute in Cargill’s favor.” *Id.* at 4a.

As Judge Higginson explained in dissent, the majority’s application of lenity to “garden-variety ambiguity” contradicts this Court’s precedent and “usurps Congress’s power to define what conduct is subject to criminal sanction.” Pet. App. 64a-65a (Higginson, J., dissenting). Holding that any ambiguity triggers lenity means “the defendant wins by default whenever the government fails to prove that a statute unambiguously criminalizes the defendant’s conduct.” *Id.* at 65a (Higginson, J., dissenting). Here, there is no ambiguity in Congress’s ban of *all* machineguns, including efforts to circumvent that ban. But even assuming *some* ambiguity, the statute should not “be construed so strictly as to defeat the obvious intention of the legislature.” *United States v. Wiltberger*, 18 U.S. (5 Wheat.) 76, 95 (1820). The Fifth Circuit’s approach would improperly do just that.

### CONCLUSION

The judgment of the court of appeals should be reversed.

Respectfully submitted,

STEPHEN J. MCINTYRE O'MELVENY & MYERS LLP 400 South Hope Street Los Angeles, CA 90071	IAN SIMMONS <i>Counsel of Record</i> SERGEI ZASLAVSKY DAVID K. ROBERTS EMILY MURPHY O'MELVENY & MYERS LLP 1625 Eye Street, NW Washington, DC 20006 (202) 383-5300 isimmons@omm.com
ANNA T. PLETCHER O'MELVENY & MYERS LLP Two Embarcadero Center 28th Floor San Francisco, CA 94111	
VINCENT WEISBAND O'MELVENY & MYERS LLP 7 Times Square New York, NY 10036	

*Attorneys for Amici Curiae*

December 21, 2023

No. 22-976

---

IN THE  
**Supreme Court of the United States**

---

MERRICK B. GARLAND, ATTORNEY GENERAL, ET AL.,

*Petitioners,*

v.

MICHAEL CARGILL,

*Respondent.*

---

ON WRIT OF CERTIORARI TO THE  
UNITED STATES COURT OF APPEALS  
FOR THE FIFTH CIRCUIT

---

**CERTIFICATE OF COMPLIANCE**

---

As required by Supreme Court Rule 33.1(h), I, Ian Simmons, a member of the bar of this Court, certify on this 21st day of December, 2023, that the Brief of Giffords Law Center to Prevent Gun Violence, Brady Center to Prevent Gun Violence, Everytown for Gun Safety, and March for Our Lives as *Amici Curiae* in Support of Petitioners in the above-captioned case contains 5,950 words, excluding the parts of the document that are exempted by Supreme Court Rule 33.1(d).

*/s/ Ian Simmons*

---

Ian Simmons

No. 22-976

---

IN THE  
**Supreme Court of the United States**

---

MERRICK B. GARLAND, ATTORNEY GENERAL, ET AL.,

*Petitioners,*

v.

MICHAEL CARGILL,

*Respondent.*

---

ON WRIT OF CERTIORARI TO THE  
UNITED STATES COURT OF APPEALS  
FOR THE FIFTH CIRCUIT

---

**PROOF OF SERVICE**

---

I, Ian Simmons, a member of the bar of this Court, hereby certify that, on this 21st day of December, 2023, all parties required by the Rules of this Court to be served have been served. Three copies of the Brief of Giffords Law Center to Prevent Gun Violence, Brady Center to Prevent Gun Violence, Everytown for Gun Safety, and March for Our Lives as *Amici Curiae* in Support of Petitioners were deposited with the U.S. Postal Service, for delivery to counsel on the attached service list.

*/s/ Ian Simmons*

---

Ian Simmons

**SERVICE LIST**

Elizabeth B. Prelogar  
SOLICITOR GENERAL  
UNITED STATES DEPARTMENT OF JUSTICE  
950 Pennsylvania Ave., N.W.  
Washington, DC 20530  
SupremeCtBriefs@usdoj.gov

*Counsel for Petitioners*

Richard Samp  
NEW CIVIL LIBERTIES ALLIANCE  
1225 19th Street, N.W., Suite 450  
Washington, DC 20036  
rasamp@verizon.net

*Counsel for Respondent*